



Documentazione guaina Tube assembly documentation Documentation gaine équipée

C339 V



Nr. di matricola
Tube No.
Nr de série

CE 0051

Questa documentazione deve essere fornita all'utilizzatore del complesso tubo guaina
The contents of this documentation must be transmitted to the user of the tube-assembly
Le contenu de cette documentation doit être transmis à l'utilisateur de la gaine équipée

Documentazione N° Documentation N° N° de Documentation	Revisione Edition Version	Data di edizione Date of release Date de l'édition	Testo originale Original text Texte original
C339V	B	29.04.2010.	italiano / italian / italien



Sommario - Table of contents - Table des matières

Sommario - Table of contents - Table des matières	2
Descrizione - Description - Description.....	3
Caratteristiche - Specifications - Spécifications.....	4
Curve di riscaldamento e raffreddamento della cuffia Tube-assembly heating and cooling curves Courbes d'échauffement et refroidissement de la gaine équipée	6
Dimensioni - Outline drawing - Schéma dimensionnel.....	7
Collegamenti connettore - Connector connections - Connexions du connecteur.....	8
Modifiche alla filtrazione - Modification of filtration - Modification de la filtration	9
Accessori - Accessories - Accessoires	10
Simbologia - Symbols - Symboles	10

Dichiarazione di conformità

Questo prodotto soddisfa i requisiti essenziali della direttiva 93/42/CEE in
accordo alle norme EN 60601.1.3 (IEC 601.1.3) e EN 60601.2.28 (IEC 601.2.28).

Declaration of conformity

This tube fulfils the essential requirements of the directive 93/42/EEC according
to standard EN 60601.1.3 (IEC 601.1.3) e EN 60601.2.28 (IEC 601.2.28).

Confirmation de conformité

Ce tube remplit les exigences essentielles de la directive 93/42/CEE en accord
avec les normes EN 60601.1.3 (IEC 601.1.3) e EN 60601.2.28 (IEC 601.2.28).



Descrizione - Description - Description

Materiale

Corpo in ottone. Riempita sottovuoto con olio isolante di particolari proprietà dielettriche, opportunamente trattato

Material

Brass body. Filled under vacuum with high dielectric insulating oil, specially processed

Matériau

Corps en laiton. Remplie sous vide avec huile isolante pour haute tension, spécialement traitée

Finitura

Bianco lucido

Finish

Glossy white

Finition

Blanc brillant

Compatibilità

Adatta per tubi mammografia IAE con corpo metallico e catodo a massa

Compatibility

Suitable for IAE mammography tubes with metal body and grounded cathode

Compatibilité

Adaptée au tubes IAE pour mammographie avec corps métallique et cathode à la masse



Caratteristiche - Specifications - Spécifications

Lunghezza totale (con connettori) Overall length with (included sockets) Longueur totale (comprenant les connecteurs)	340 mm	
Diametro massimo Max. diameter Diamètre maximal	140 mm	
Peso netto del complesso tubo-guaina Tube assembly net weight Poids net de la gaine équipée	13 kg	
Limiti di temperatura per il trasporto e lo stoccaggio Temperature limits for transportation and storage Limites de température pour le transport et le stockage	-10°C ÷ +80°C	
Limiti di umidità per il trasporto e lo stoccaggio Humidity limits for transportation and storage Limites d'humidité pour le transport et le stockage	max. 80%	
Alta tensione nominale Nominal X-Ray tube assembly voltage Haute tension nominale de la gaine équipée	49 kV	
Alta tensione anodo - massa High voltage anode to ground Haute tension par rapport à la masse	49 kV	
Alta tensione catodo - massa High voltage cathode to ground Haute tension par rapport à la masse	0 kV	
Massima energia accumulabile nel complesso tubo-guaina Maximum tube assembly heat content Chaleur maximale retenue dans la gaine équipée	320 kJ	
Dissipazione termica continua massima senza ventilatore Maximum continuous heat dissipation without fan Dissipation thermique continue maximale sans ventilateur	80 W	
Filtrazione inerente del complesso tubo-guaina Tube assembly inherent filtration Min. filtration inhérente de la gaine équipée	0.5 mm Be	
Filtrazione addizionale Additional filtration Filtration additionnelle	0.03 mm Mo	
Fattori di carico per la misura della radiazione di fuga Loading factor for leakage radiation determination Paramètres de charge pour la mesure du rayonnement de fuite	49 kV 4 mA	(IEC 601.1.3 EN 60601.1.3)
Radiazioni di fuga massima a 1 metro dalle macchie focali Maximum leakage radiation at 1 m from focal spots Rayonnement de fuite maximal à 1 m du foyer	45 µGy/h (5 mR/h)	



Dati dello statore - Stator data - Données du stator

<i>Alimentazione / Operation / Alimentation</i>		50 Hz		170 Hz	
		lancio - start - démarrage	mant. - run - maintien	lancio - start - démarrage	mant. - run - maintien
Tensione - Voltage - Tension	V	220	40	440	100
Principale - Line - Principal	A	7.1	1.3	5.7	0.9
Ausiliario - Phase shift - Auxiliaire	A	3.5	0.8	8.2	1.4
Comune - Common - Commun	A	7.8	1.5	9.2	2.1
Capacità del condensatore Condenser capacity Capacité du condensateur		25 - 40 µF		4.5 µF	
Max. numero di lanci Max. starting cycles Max. nombre de démarrages		2 / min		1 / min	
Energia e potenza immessa dallo statore Stator input energy and power Energie et puissance introduites par le stator		1550 J	60 W	3250 J	210 W
<p><i>Valori indicativi: possono variare con il tipo di starter Indicative values: may change with the starter type Valeurs indicatives: peuvent varier avec le type de démarreur</i></p>					

**Resistenza degli avvolgimenti
Windings resistance values
Résistance des enroulements**

principale:
phase: 20 Ω
principal:
ausiliario:
phase shift: 40 Ω
auxiliaire:

Tubo / Insert / Tube	Tempi di lancio Starting time Temps de démarrage		Tempi di frenatura Braking time Temps de freinage
	2800/3400 min⁻¹	10000 min⁻¹	
XM12 / XM15 / XM1016	0.9 sec	0.8 sec	1.6 sec
<p><i>Valori indicativi: possono variare con il tipo di starter Indicative values: may change with the starter type Valeurs indicatives: peuvent varier avec le type de démarreur</i></p>			



<u>Classificazione</u>	<u>Classification</u>	<u>Classification</u>	
Classe di protezione IEC601-1	IEC 601-1 equipment class	CEI 601-1 appareil de la classe	I
Tipo di protezione IEC 601-1	IEC 601-1 equipment type	CEI 601-1 appareil du type	B
Classe 93/42/CEE	93/42/EEC class	93/42/CEE classe	IIb

Sicurezza termica

Per la protezione termica é presente un termostato bimetallico all'interno della cuffia, collegato in serie al cavo comune dello statore, che si apre a 80°C.

Thermal safety

For thermal protection there is a bimetallic thermal switch, internally assembled, series connected with stator common cable (switches off at 80°C).

Sécurité thermique

Pour la protection thermique un interrupteur thermique à bimétal est présent, monté à l'intérieur de la gaine en série avec le conducteur commun du stator (ouvre à 80°C)

Curve di riscaldamento e raffreddamento della cuffia
Tube-assembly heating and cooling curves
Courbes d'échauffement et refroidissement de la gaine équipée

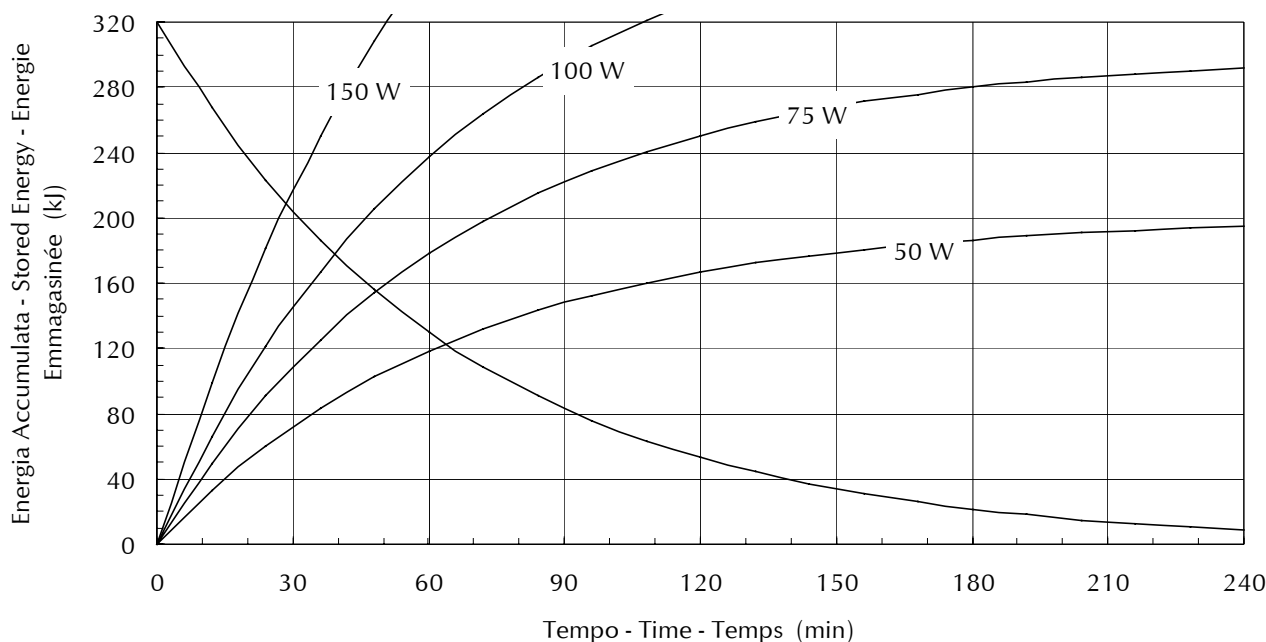

Dimensioni - Outline drawing - Schéma dimensionnel

Vista frontale / Frontal view / Vue frontale

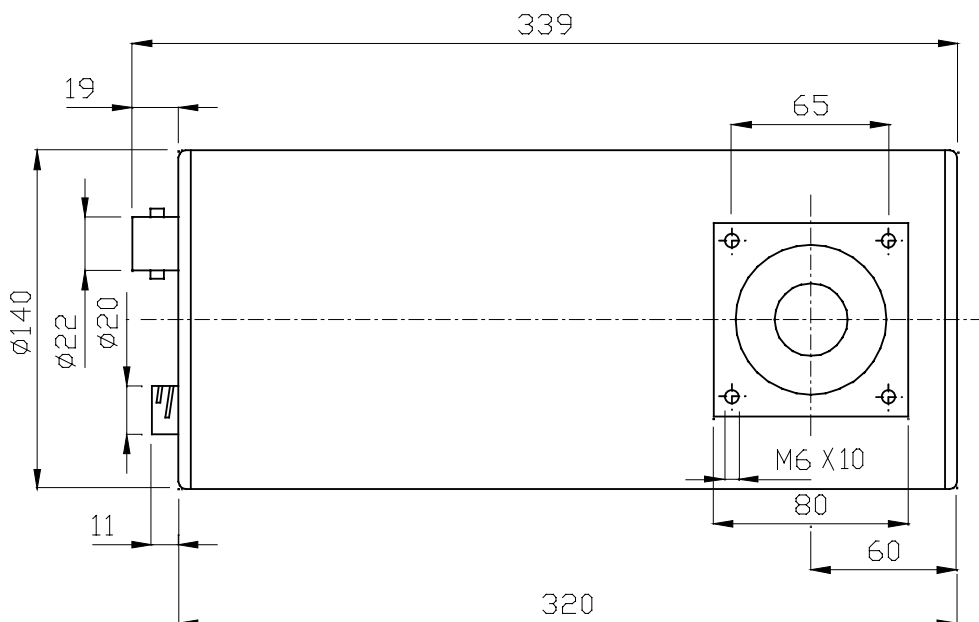

Vista laterale / Housing lateral view / Vue latérale

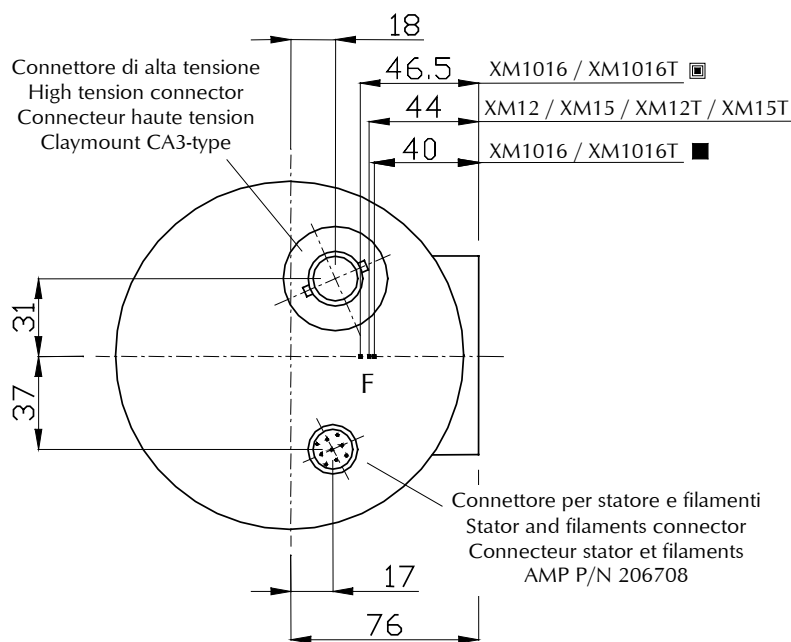

Dimensioni in mm / Dimensions in mm / Dimensions en mm

F: Posizione delle macchie focali / Focal spots position / Position des foyers

Collegamenti connettore - Connector connections - Connexions du connecteur

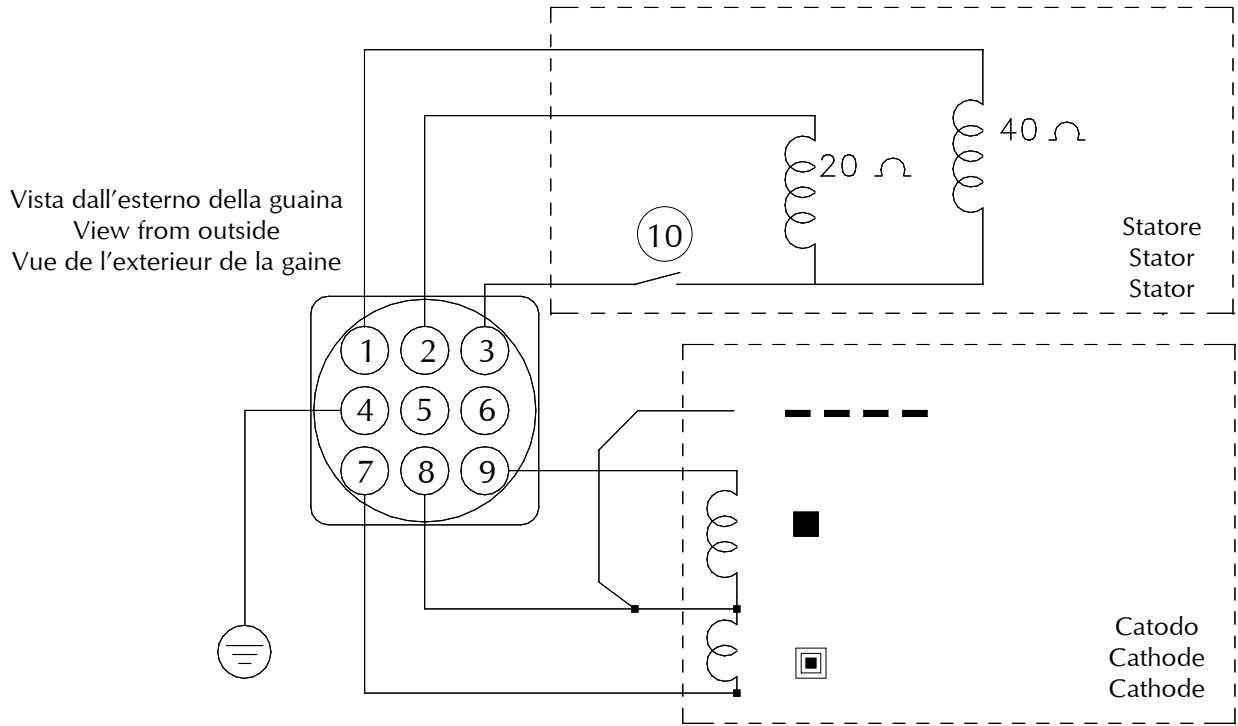

Statore - Stator - Stator

Principale	Line	Principal	2
Comune	Common	Commun	3
Ausiliario	Phase shift	Auxiliaire	1
Termostato interno normalmente chiuso apre a: 80° C ± 4° C	Internal thermal switch, normally closed opens at: 80° C ± 4° C	Sécurité thermique interne, contact fermé au repos ouvre à: 80° C ± 4° C	10

Catodo - Cathode - Cathode

Fuoco piccolo	Small focal spot	Petit foyer	7
Fuoco grande	Large focal spot	Grand foyer	9
Comune <i>Il cavo del comune di filamento deve essere collegato a terra o direttamente oppure attraverso il circuito di misura mA</i>	Common <i>Common filament conductor must be connected to ground either directly or through mA measurement circuit</i>	Commun <i>Le câble commun du filament doit être raccorder à la terre ou directement travers le circuit de mesure mA</i>	8

Modifiche alla filtrazione - Modification of filtration - Modification de la filtration

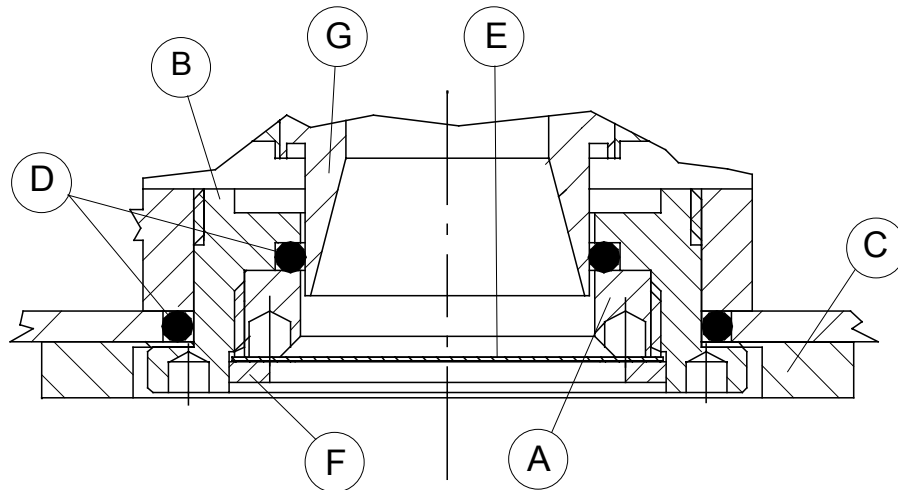

Ghiera finestra	Windows nut	Bague de la fenêtre	A
Flangia finestra	Filter 0.03 mm Mo	Filtre 0.03 mm Mo	B
Blocco finestra	Window block	Bloc de la fenêtre	C
O-Ring	O-Ring	O-Ring	D
Filtro 0.03 mm Mo	Filter 0.03 mm Mo	Filtre 0.03 mm Mo	E
Seeger	Seeger	Seeger	F
Tubo a raggi X	X-Ray tube	Tube	G

Attenzione

Il complesso tubo guaina viene fornito con un filtro addizionale da 0.03 mm Mo a disposizione dell'installatore.

E' compito dell'installatore verificare che il complesso radiante risulti conforme alle prescrizioni indicate dalla norma IEC 601.1.3 (CEI EN 60601.1.3) utilizzando eventualmente il filtro addizionale a disposizione.

Note: per montare il filtro addizionale seguire le istruzioni ad esso allegate.

Warning

The tube assembly is supplied with an additional 0.03 mm Mo filter available to the installer.

It is the responsibility of the installer to take care that the radiation source assembly complies with the IEC 601.1.3 (CEI EN 60601.1.3).

If needed the supplied additional filter may be used.

Note: to install the additional filter, please follow the attached instruction.

Attention

L'ensemble gaine-tube est fourni à l'origine avec une filtration additive de 0.03 mm Mo au gré de l'installateur.

Il est de la compétence de l'installateur de vérifier que l'ensemble radiogène utilisé soit en conformité avec les indications relatives à IEC 601.1.3 (CEI EN 60601.1.3) d'utiliser la filtration additive mise à disposition à cet effet.









Note: pour monter le filtre additionnel prions suivre les instructions attachées.

Accessori - Accessories - Accessoires

Accessori forniti	Standard accessories	Accessoires fournis	Cod
Filtro 0.03 mm Mo addizionale	Additional filter 0.03 mm Mo	Filtre 0.03 mm Mo additionnel	M2707
Grasso al silicone	Silicon grease	Graisse de silicone	0270A10

Accessori opzionali	Optional accessories	Accessoires optionnels	Cod
Cavo con connettore per statore e filamenti	Stator and filaments cable with connector	Câble stator et filaments avec connecteur	APAB0

Simbologia - Symbols - Symboles

	Tubo a raggi X	X-ray tube	Tube radiogène
	Guaina a raggi X	X-ray source assembly	Gaine à rayonnement X
	Filtrazione	Filtration	Filtration
	Fuoco piccolo	Small focal spot	Petit foyer
	Fuoco grande	Large focal spot	Grand foyer
	Apparecchio di Tipo B	Type B equipment	Appareil de type B
	Posizione fuoco	Focal spot position	Position des foyers
	Terra di protezione	Protective earth (ground)	Terre de protection
	Tensione pericolosa	Dangerous voltage	Tension dangereuse